

Conditions: Indoor Outdoor Dry Wet Blue Groove Hard Packed
Composition: Astroturf Clay Carpet Dirt Grass Other: _____
Size: Open Medium Tight **Traction:** High Medium Low **Surface:** Smooth Medium Bumpy

Differential
 Ball: _____ Gear - Oil: _____

Tire & Inserts

	Front	Rear
Tire:	_____	_____
Insert:	_____	_____
Notes:	_____	

Electronics
 Motor: _____ Spur/Pinion: _____
 Battery: _____
 Battery Position: _____
 ESC: _____
 ESC Settings: _____
 Servo: _____ Receiver: _____

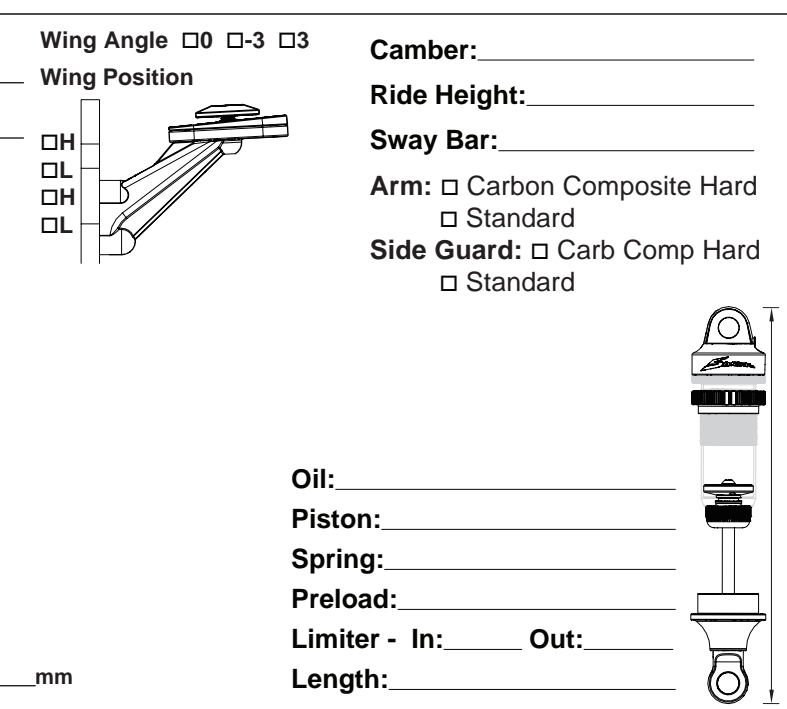
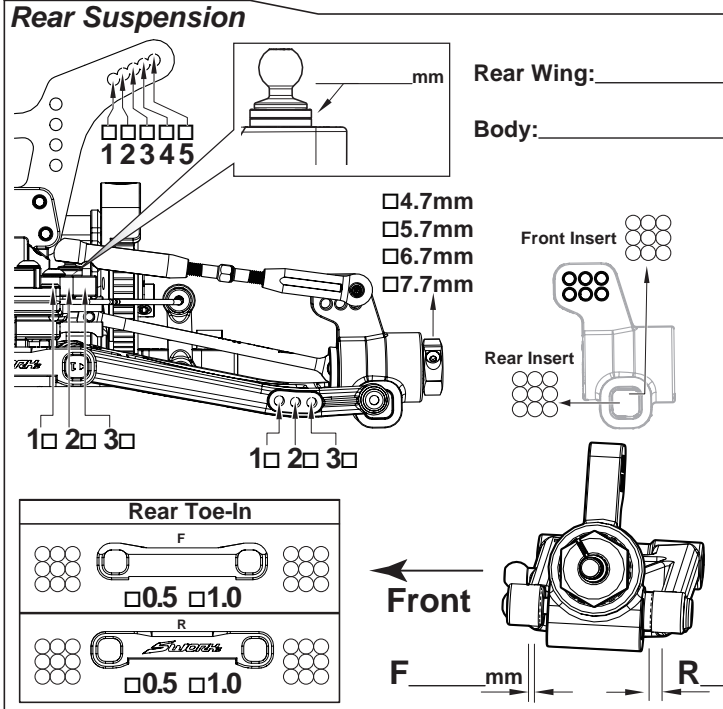
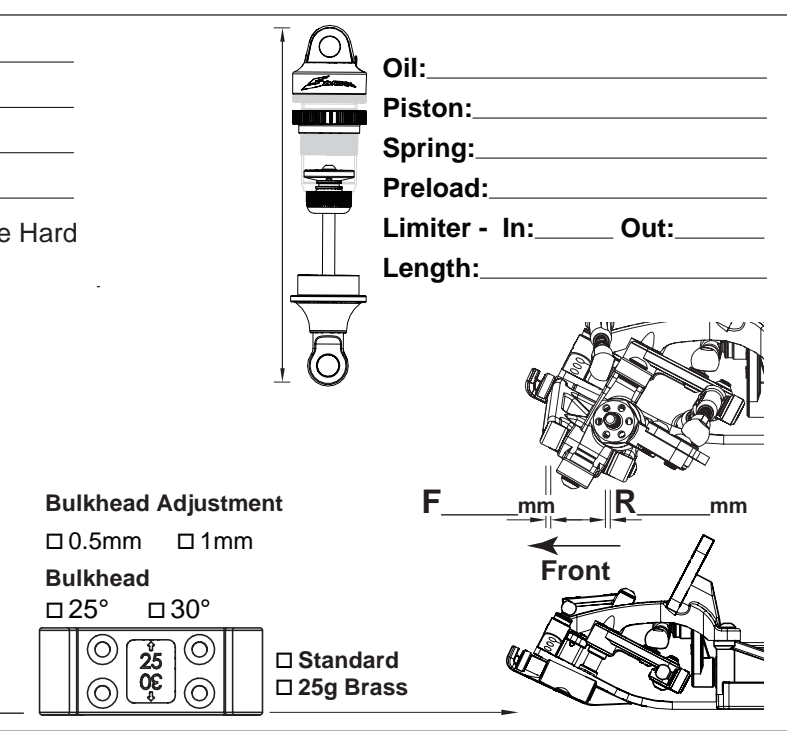
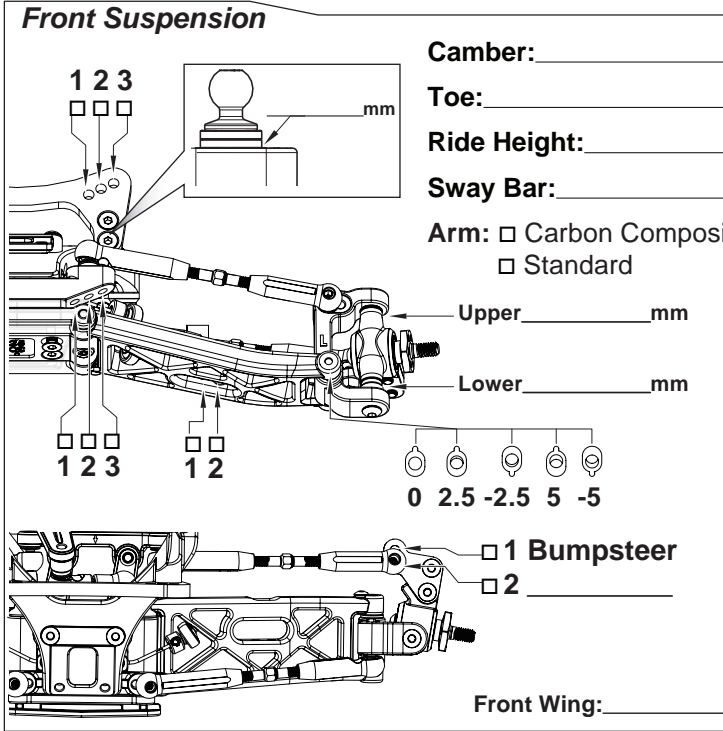

Notes