

NAME: _____ DATE: _____ EVENT: _____ TRACK: _____

TRACK CONDITIONS

- Indoor Tight Smooth Hard Packed Blue Groove Dry Low Bite Med Bite High Bite
 Outdoor Open Rough Loose/Loamy _____ Wet Dusty _____

FRONT SUSPENSION

Ride Height	mm
Camber	°
Toe	°
Sway Bar	mm

Notes

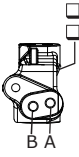
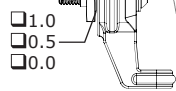
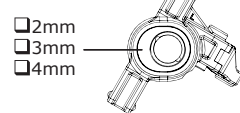
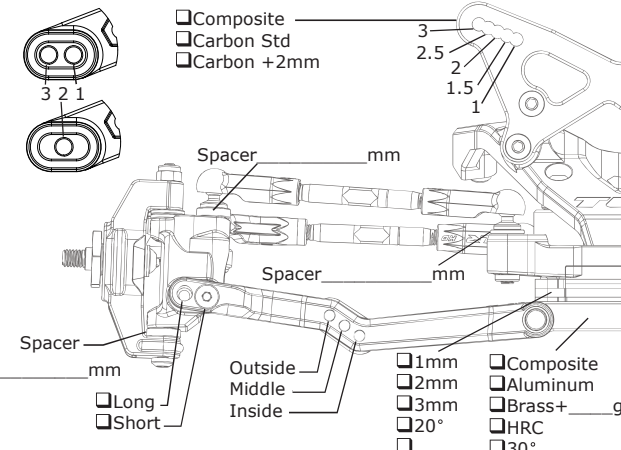
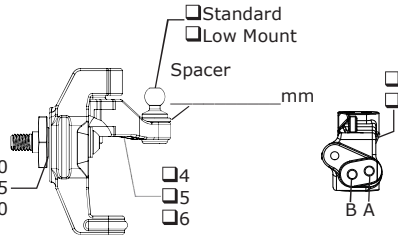
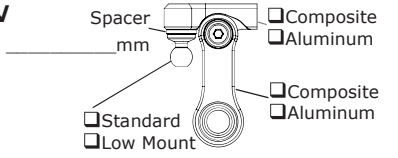

REAR SUSPENSION

Ride Height	mm
Camber	°
Sway Bar	mm

Notes

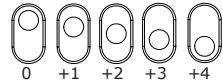
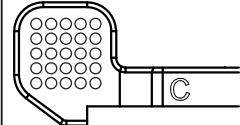
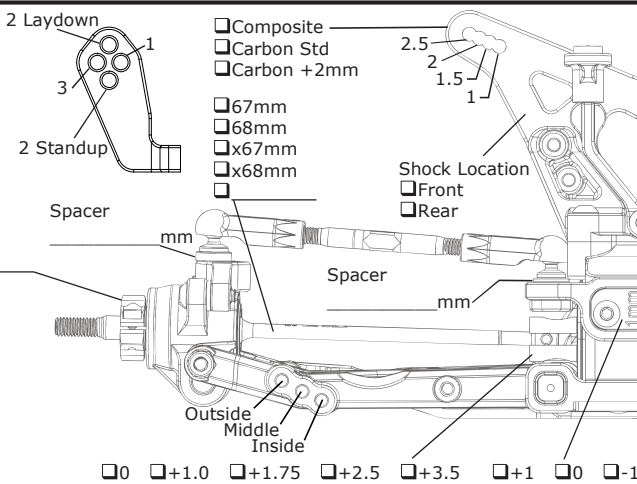
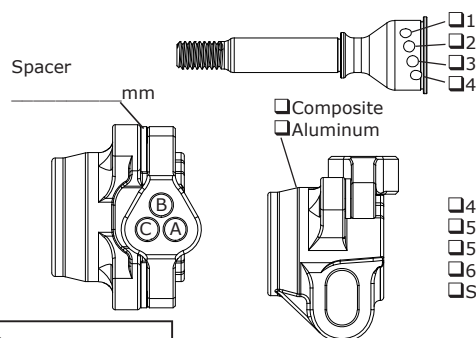

- 0 +1.0 +1.75 +2.5 +3.5 +1 0 -1

CHASSIS

DRIVETRAIN	
Differential Type	<input type="checkbox"/> Ball <input type="checkbox"/> Gear
Setting/Fluid	
Internal Gears	<input type="checkbox"/> Steel <input type="checkbox"/> Composite
Planetary Gears	<input type="checkbox"/> 2 <input type="checkbox"/> 4
Slipper	<input type="checkbox"/> Slipper <input type="checkbox"/> Direct Drive
Slipper Pads	<input type="checkbox"/> Torque/Yellow <input type="checkbox"/> Drive/Orange

AERODYNAMICS	
Body	
Fr Wing	
Rr Wing	
Wicker	
Angle	°
Notes	

TIRES	Front	Rear
Tires		
Compound		
Insert		
Additive		
Wheel		
Notes		

SHOCKS	Front	Rear
Shock Cap		
Oil		
Piston	<input type="checkbox"/> Thin	<input type="checkbox"/> Thin
Spring		
Limiters Int	mm	mm
Shaft Diam	<input type="checkbox"/> 3.0mm <input type="checkbox"/> 3.5mm	<input type="checkbox"/> 3.0mm <input type="checkbox"/> 3.5mm
Limiters Out	mm	mm
Stroke	mm	mm
Eyelet	<input type="checkbox"/> Std <input type="checkbox"/> +2mm	<input type="checkbox"/> Std <input type="checkbox"/> +2mm
Spring Cup	<input type="checkbox"/> Low <input type="checkbox"/> Mid <input type="checkbox"/> High	<input type="checkbox"/> Low <input type="checkbox"/> Mid <input type="checkbox"/> High
Notes		

ELECTRONICS	
Radio	ESC
Servo	Th Prof
Battery	Timing
Battery Wt	g Initial Brake
Motor	Drag Brake
Ratio	/ Th/Bra EPA /

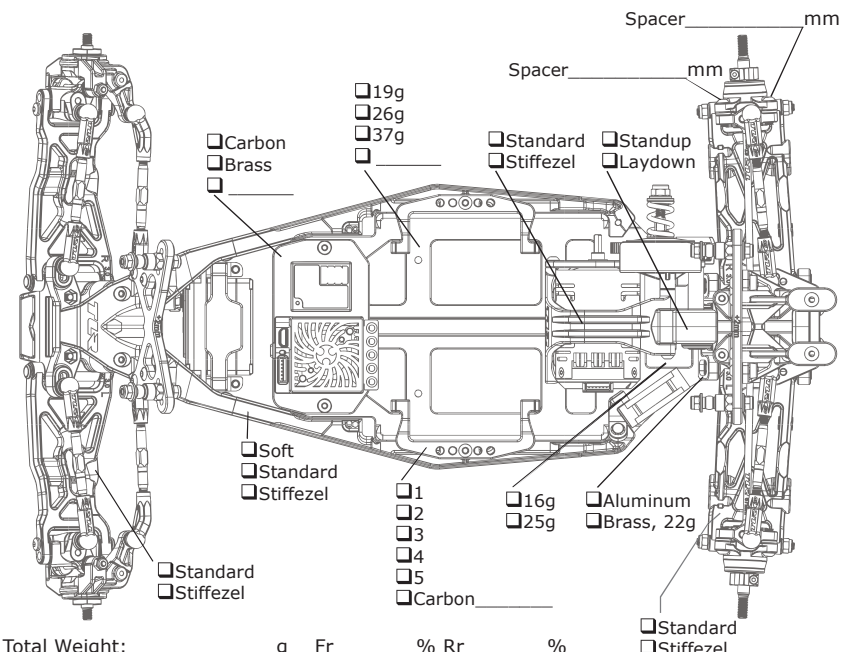

Total Weight: _____ g Fr _____ % Rr _____ %