

<b>Driver &amp; Event</b>
Name <i>Grant Fribbens</i>
Date <i>06/05/2018</i> Event <i>TORCH Summer R1</i>
Weather <i>Sunny and hot 18 - 25</i>
Result <i>A3</i>

<b>Electrics &amp; Chassis</b>
E.S.C <i>Hobbywing V2.1 120A</i>
Servo <i>Sanwa SRG-CT</i>
Reciever <i>Futaba R304SB</i> Lipo <i>Absima LCG 3800</i>
Shorty LiPo Front <input type="checkbox"/> Middle <input type="checkbox"/> Rear <input checked="" type="checkbox"/>
Centre Topdeck Yes <input type="checkbox"/> No <input checked="" type="checkbox"/>
Front Topdeck Thickness 2.5mm <input checked="" type="checkbox"/> 3.0mm <input type="checkbox"/>
Rear Topdeck Thickness 2.5mm <input checked="" type="checkbox"/> 3.0mm <input type="checkbox"/>

<b>Motor &amp; Gearing</b>
Motor <i>SkyRC ARES PRO 6.5</i>
Rotor Diameter <i>STD</i> mm
Timing <i>20</i> Deg
Spur <i>83</i>
Pinion <i>20</i>

<b>Track Conditions</b>
Grip Level High <input type="checkbox"/> Med <input checked="" type="checkbox"/> Low <input type="checkbox"/>
Type Tight <input type="checkbox"/> Open <input type="checkbox"/> Mixed <input type="checkbox"/>
Surface Clay <input type="checkbox"/> Astro <input checked="" type="checkbox"/> Grass <input type="checkbox"/>
Mixed <input type="checkbox"/> Carpet <input type="checkbox"/>
Condition Smooth <input type="checkbox"/> Bumpy <input checked="" type="checkbox"/>

<b>Wheels &amp; Tyres</b>
Rr Tyre <i>U6826 Rear Dart Yellow</i>
Rr Wheel <i>Kit</i>
Rr Insert <i>U6747 Rear tubby</i>
Fr Tyre <i>U6825 Dart Yellow 4wd</i>
Fr Wheel <i>Kit</i>
Fr Insert <i>U6746 Front tubby</i>

<b>Other settings</b>
Car Weight <i>1684g</i>
Alloy Wing Mount High <input type="checkbox"/> Low <input type="checkbox"/>
Rear Wing Gurney Height mm
Front Wing Small <input type="checkbox"/> Big <input type="checkbox"/>
Front Wing Gurney Height mm
Slipper 2Plate <input checked="" type="checkbox"/> 3Plate <input type="checkbox"/> 4Plate <input type="checkbox"/>
Rear Hex 0 <input checked="" type="checkbox"/> 0.75 <input type="checkbox"/> 1.5 <input type="checkbox"/>
Front Hex 0 <input checked="" type="checkbox"/> 0.75 <input type="checkbox"/> 1.5 <input type="checkbox"/>

<b>Differential</b>
Diff Oil F..... <i>12000</i> cSt R..... <i>12000</i> cSt
Dif Height F High <input type="checkbox"/> Mid <input type="checkbox"/> Low <input checked="" type="checkbox"/>
Dif Height R High <input checked="" type="checkbox"/> Mid <input type="checkbox"/> Low <input type="checkbox"/>

<b>Front Shocks</b>
Oil..... <i>500</i> cSt Spring <i>Core RC Blue</i> lb/in
Shock Cap Vented <input checked="" type="checkbox"/> Sealed <input type="checkbox"/> Aeration <input type="checkbox"/>
Piston <i>U7433</i> Drilled <input checked="" type="checkbox"/> Hole Size..... <i>1.5</i> mm
Internal Limiters..... <i>0.5</i> mm Kashima Body No <input checked="" type="checkbox"/> Yes <input type="checkbox"/>



21.6 mm

<b>Rear Shocks</b>
Oil..... <i>400</i> cSt Spring <i>Core RC Red</i> lb/in
Shock Cap Vented <input checked="" type="checkbox"/> Sealed <input type="checkbox"/> Aeration <input type="checkbox"/>
Piston <i>U7433</i> Drilled <input checked="" type="checkbox"/> Hole Size..... <i>1.6</i> mm
Internal Limiters..... <i>0.5</i> mm Kashima Body No <input checked="" type="checkbox"/> Yes <input type="checkbox"/>
Shock Stand Off Spacing..... <i>0</i> mm

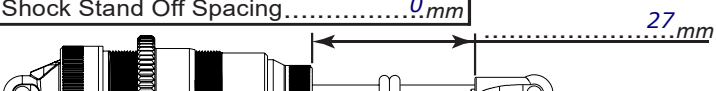

27 mm

<b>Front Suspension</b>
Toe:..... <i>0</i> Deg
Yoke: 8° <input type="checkbox"/> 10° <input checked="" type="checkbox"/> 12° <input type="checkbox"/>
Anti Roll Bar: None <input type="checkbox"/> 1.2 <input type="checkbox"/> 1.4 <input checked="" type="checkbox"/> 1.6 <input type="checkbox"/> 1.8 <input type="checkbox"/> 2.0 <input type="checkbox"/>
Link Washer ..... <i>2</i> mm
Ride Height:..... <i>17</i> mm
Camber at Ride Height:..... <i>1.5</i> Deg
Wheelbase: Short <input type="checkbox"/> Long <input checked="" type="checkbox"/>
Bump Steer Washer:.....mm
Hub Spacer: High <input checked="" type="checkbox"/> Low <input type="checkbox"/>
Driveshaft: Kit <input checked="" type="checkbox"/> Roche <input type="checkbox"/>
Pin Angle: 8° <input type="checkbox"/> 10° <input checked="" type="checkbox"/> 12° <input type="checkbox"/>
Pin Width: Narrow <input type="checkbox"/> Mid <input checked="" type="checkbox"/> Wide <input type="checkbox"/>
Shock Mount: C/F <input type="checkbox"/> S2 <input type="checkbox"/>

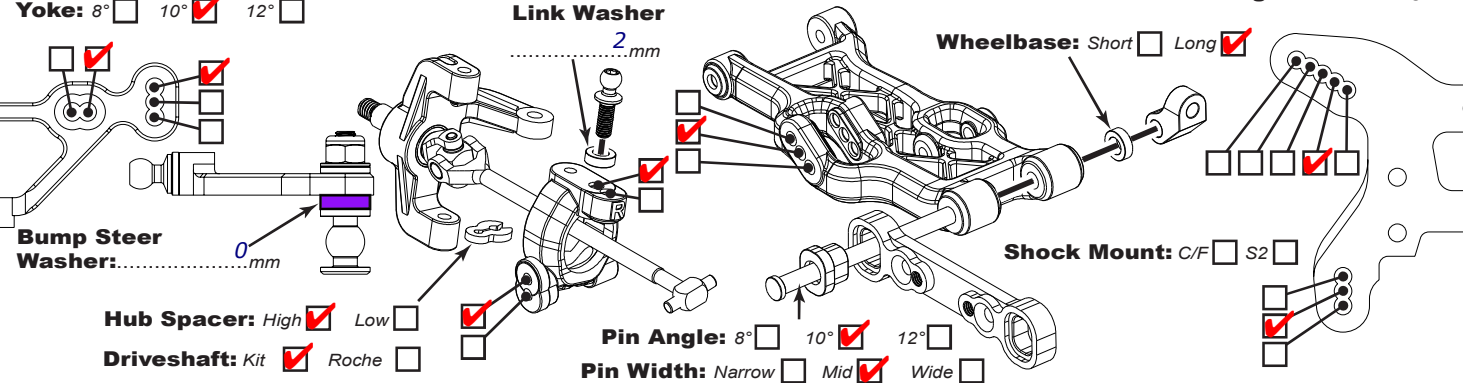

<b>Rear Suspension</b>
Toe In (Kit Blocks): 3° <input checked="" type="checkbox"/> 2.5° <input type="checkbox"/>
Toe In (3.5°/2° Blocks): 3.5° <input type="checkbox"/> 2° <input type="checkbox"/>
Toe In (4°/1.5° Blocks): 4° <input type="checkbox"/> 1.5° <input type="checkbox"/>
Anti-squat: 1° <input type="checkbox"/> 2° <input checked="" type="checkbox"/> 3° <input type="checkbox"/> 4° <input type="checkbox"/>
Anti Roll Bar: None <input type="checkbox"/> 1.2 <input type="checkbox"/> 1.4 <input checked="" type="checkbox"/> 1.6 <input type="checkbox"/> 1.8 <input type="checkbox"/> 2.0 <input type="checkbox"/>
Ride Height:..... <i>18</i> mm
Camber at Ride Height:..... <i>1.5</i> Deg
Wheelbase: Short <input type="checkbox"/> Med <input checked="" type="checkbox"/> Long <input type="checkbox"/>
Shock Mount: C/F <input checked="" type="checkbox"/> S2 <input type="checkbox"/>
Wing Mount: Alloy <input type="checkbox"/> Kit <input checked="" type="checkbox"/>
Wing Washer: No <input type="checkbox"/> Yes <input checked="" type="checkbox"/>
Hub Washers:.....mm
Link Washer ..... <i>2</i> mm
Rear Strap: High Pin (With front Riser) <input type="checkbox"/> Low Pin (Kit) <input checked="" type="checkbox"/>
Hub Carrier: Kit <input checked="" type="checkbox"/> Alloy <input type="checkbox"/>
Brass insert: Hi-Pin <input type="checkbox"/> Low-Pin <input type="checkbox"/>
Link Mount: Kit <input checked="" type="checkbox"/> Alloy <input type="checkbox"/>

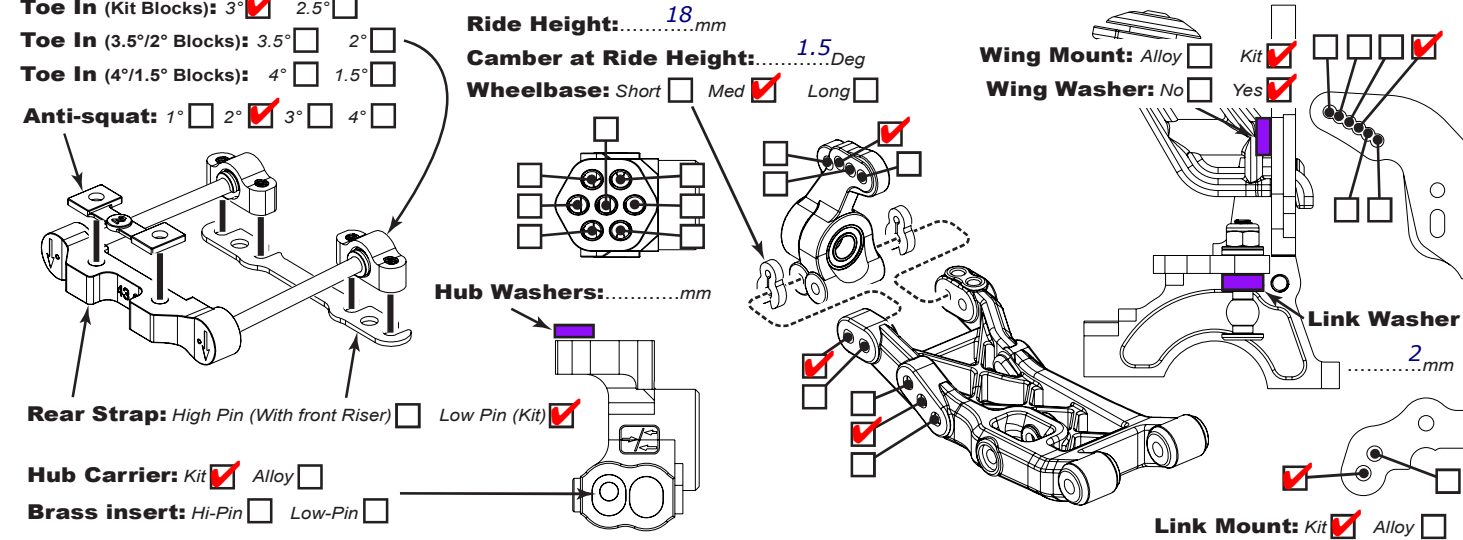

**Notes**

3d printed shock spring seats similar to U4890  
 HW V2.1 ESC Settings Boost 13 Turbo 18  
 Front tyres: Inner row and outer two rows removed  
 U4285 Pro blue seals in shocks  
 Old orange o-rings on all ball studs  
 Nail varnish on inside and outside of bearings for tighter fit.  
 Finish line teflon grease on the gears